



I&J FISNAR INC.

2-07 Banta Place, Fair Lawn, NJ 07410-3002 USA
TEL. (201)796 - 1477 FAX. (201)794 - 7034
info@ijfnar.com http://www.ijfnar.com

P/N 561930-LF
REV. B JUN 07

©2007 I&J FISNAR INC.

710PTNM-LF PINCH TUBE VALVE

OPERATING MANUAL



The PINCH TUBE VALVE provides a wide degree of control for continuous or micro shot applications of low to semi-viscous fluids.

The “ON/OFF” control is achieved by automatically opening and pinching a molded polyethylene tube assembly. The adjustable degree of opening or releasing the pinch closing on the tube assembly determines the shot size or flow rate. In addition, the air-powered valve can be timed to develop desired shot sizes. Finally, a wide range of needle tips can be used to further refine the amount of the dispensed output.

The only part of the valve making contact with the fluid being dispensed is the disposable tube assembly.

OPERATION PROCEDURE

This valve is unique inasmuch as the design prevents rotation of the “SHUT-OFF” blade, allowing the use of a narrow “chisel point” head on the “SHUT-OFF” piston. This edge design provides the fine degree of control necessary to make very small shots.

This is accomplished by connecting the air piston (9) to the “SHUT-OFF” piston (2) with two push rods, which pass on either side of the pump tube (7).

Adjustment of the knob (5) controls the travel of the “SHUT-OFF” piston by limiting its reverse movement. The “SHUT-OFF” piston is moved by the push rods of the air piston.

The travel of the “SHUT-OFF” piston determines the amount of opening for the pump tube and, when coupled with a time control, determines the shot size.



I&J FISNAR INC.

2-07 Banta Place, Fair Lawn, NJ 07410-3002 USA
TEL. (201)796 - 1477 FAX. (201)794 - 7034
info@ijfisnar.com http://www.ijfisnar.com

TECHNICAL SERVICE INFORMATION

PRODUCT DESCRIPTION

710PTNM-LF PINCH TUBE VALVE

SET-UP PROCEDURE

The valve will operate in any position, providing the supply source is pressurized. If gravity feed is being used, the inlet side of the valve must be in an upright, vertical position and the reservoir must always be six inches above the center line of the valve. Gravity supply will work only with very thin pourable materials.

A threaded mounting hole in the side of the body accepts a ½” diameter rod (1).

The valve requires a minimum of 60 psi to properly operate the opening piston. The shut-off function is achieved by an internal spring.

The air line to the valve should be attached to a three-way air supply valve (manual or automatic). Actuating this valve will open the micro shot valve. The open time determines the shot size.

Connect the supply line (included with the valve) to the reservoir. If using a pressurized reservoir, use the enclosed adapters to provide a connection point to the supply tube. If gravity flow can be used, a barrel reservoir can be mounted directly to the fluid inlet. Refer to the Tech Service Information Sheet for application suggestions.

BE SURE ALL AIR HAS BEEN BLED FROM THE SUPPLY LINE WHEN TRYING TO OBTAIN REPEATABLE SHOT SIZES OR UNINTERRUPTED FLOW.

NOTE: if material drips from the tip, follow instructions below

- A. Fully close the adjustment knob (5) to form a “crease” in the pinch tube.
- B. Operate the valve and slowly open the adjustment knob until material comes out from the tip.
- C. Adjustment of knob controls the travel of “shut-off” piston (2) by limiting its reverse movement.
- D. Adjust the knob position per shot size requirement.
- E. Tighten the lock nut (16) to secure the shot size adjustment.



I&J FISNAR INC.

2-07 BANTA PLACE - FAIR LAWN - NJ 07410-3002 - USA
 (201) 796-1477 FAX NO. (201) 794-7034
 E-MAIL info@IJFISNAR.com
 INTERNET www.IJFISNAR.COM

TECHNICAL SERVICE MANUAL

SHEET 1 OF 1

REVISION

A	02/05/2007
B	06/20/2007

PRODUCT
DESCRIPTION

710PTNM-LF DISPENSING VALVE

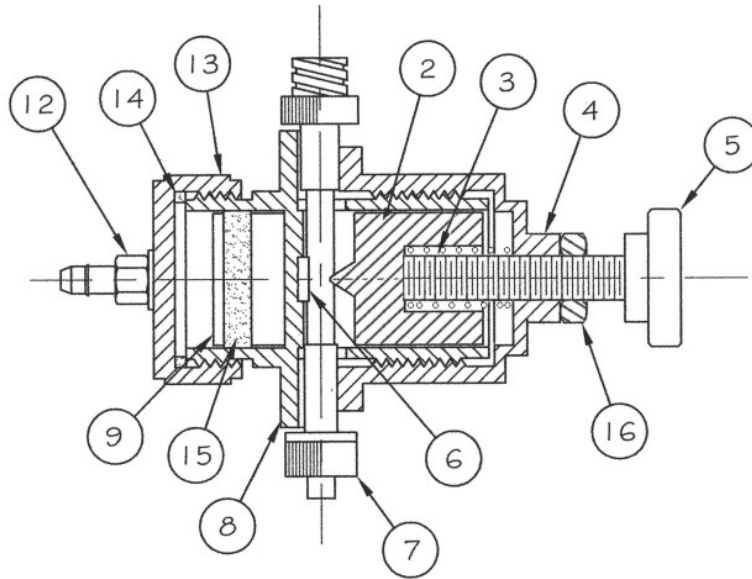
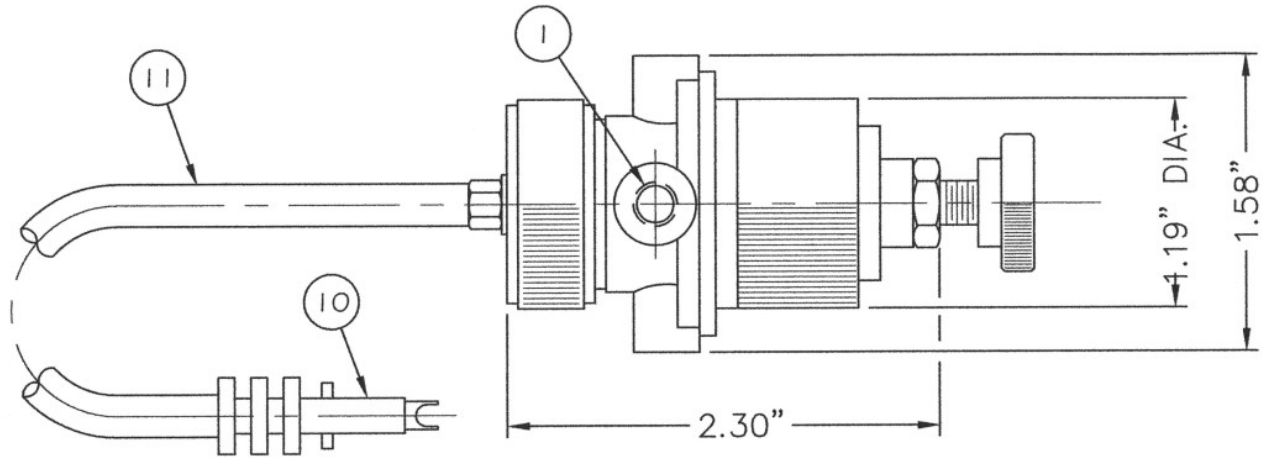

NO.	PART NUMBER	DESCRIPTION	QTY.	NO.	PART NUMBER	DESCRIPTION	QTY.
11	560705-BULK	TUBING	3ft				
10	580035H	CONNECTOR	1				
9	580027NM-LF	PISTON	1				
8	580022NM	BODY	1				
7	580038A	DISPENSE TUBE	1				
6	580026NM	PINCH CUSHION	1				
5	580029NM	ADJ. KNOB	1	16	580036NM	1/4-28 JAM NUT	1
4	580024NM-LF	FLANGE CAP	1	15	580031NM	U-CUP SEAL	1
3	580028NM-LF	SPRING	1	14	580030NM	GASKET	1
2	580025NM	SHUT-OFF PISTON	1	13	580023NM-LF	CYLINDER CAP	1
1	580033NM	ROD MOUNT	1	12	580032A	HOSE BARB WITH WASHER	1

DRAWN BY: **DARKO KITANSKI**

DATE DRAWN: 02/05/2007

FILE NAME: 710PTNM-LF.cdr



I&J FISNAR INC.

2-07 BANTA PLACE - FAIR LAWN - NJ 07410-3002 - USA
(201) 796-1477 FAX NO. (201) 794-7034
E-MAIL info@IJFISNAR.com
INTERNET www.IJFISNAR.COM

TECHNICAL SERVICE MANUAL

SHEET 1 OF 1

REVISION

A 06/20/2007

PRODUCT DESCRIPTION **710PTNM-LF PINCH TUBE ASSEMBLY**

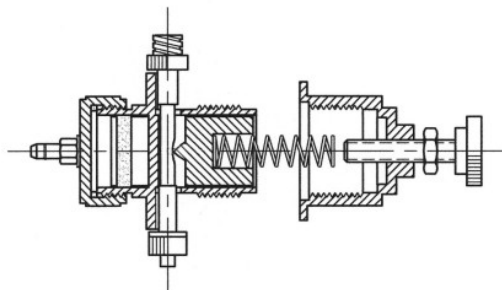
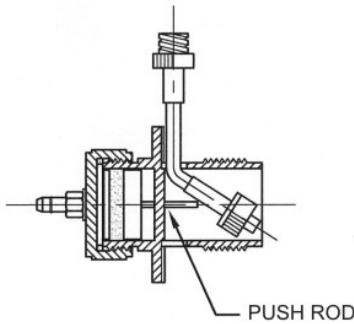
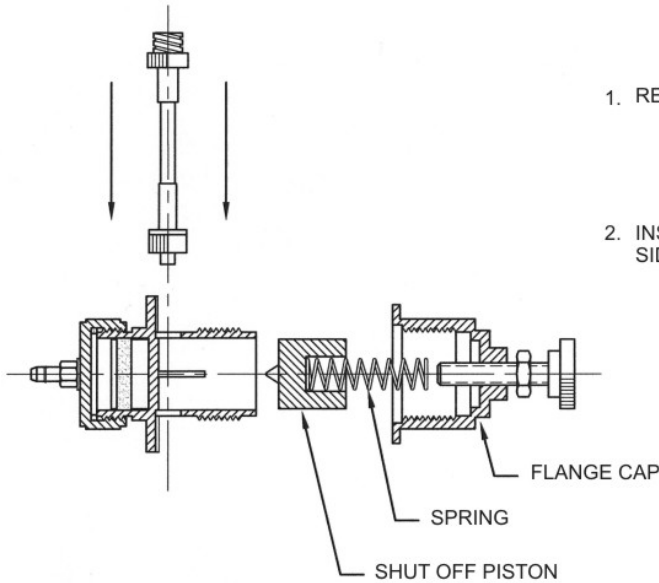

PINCH TUBE ASSEMBLY: 580038 0.07 I.D. STD.
580037A 0.10 I.D. OPT.