

User Manual Diaphragm Valve DV-5625 Series



Quality
made in
Germany



Dear Customer

Thank you for purchasing the diaphragm valve DV-5625.
These operating instructions are intended for simple and safe operation of the valve.
Please read these instructions carefully before putting the valve into operation and observe the given safety instructions.

Your Vieweg Team

Contents

1	Introduction	4
2	Spezifications	4
3	Part description	5
4	Operation Principles	6
5	Operating Procedure	7
6	Commissioning	7
7	Maintenance	9
	7.1 Cleaning	9
	7.2 Dismantling the valve	9
	7.3 Assembling the valve	9
8	Detail drawings & dimensions	10
9	Exploded drawing	11
10	Parts and spare parts list	11

1 Introduction

The valve DV-5625 is a diaphragm valve designed for precise flow control of low to medium viscosity materials (under 10,000 cps). The valve is ideal for dispensing cyanoacrylates, reagents, electrolytes, glues, solvents, paints, alcohol and other volatile substances. Shot sizes may be fine tuned by turning the stroke adjustment knob at the top of the valve.

2 Spezifications

	DV-5625-U	DV-5625-SS
Operating Air Pressure	4,0 – 6,0 bar	4,0 – 6,0 bar
Max. Delivery Pressure	5 bar	5 bar
Max. number of cycle	500 cycles /min	500 cycles /min
Flux (KV value)	300 ml / min (water at 2 bar)	300 ml / min (water at 2 bar)
Min. Shot Size	0,001 ml (material dependant)	0,001 ml (material dependant)
Valve Structure	Diaphragm Valve	Diaphragm Valve
Weight	ca. 87 g	ca. 87 g
Driving Part Materials	Body : AL (Hard coated, Black) Piston : SUS303 Piston Seal : NBR	Body : AL (Hard coated, Black) Piston : SUS303 Piston Seal : NBR
Wetted Part Materials	Valve Head : UHMW-PE (option : PTFE, PEEK, Acetal) Diaphragm : UHMW-PE	Valve Head : Stainless Steel (option : PTFE, PEEK, Acetal) Diaphragm : UHMW-PE
Connecting Ports	Operating Air Inlet: M5 Material Inlet: 1/8" Material Outlet: Luer Lock	Operating Air Inlet: M5 Material Inlet: 1/8" Material Outlet: Luer Lock

3 Part description

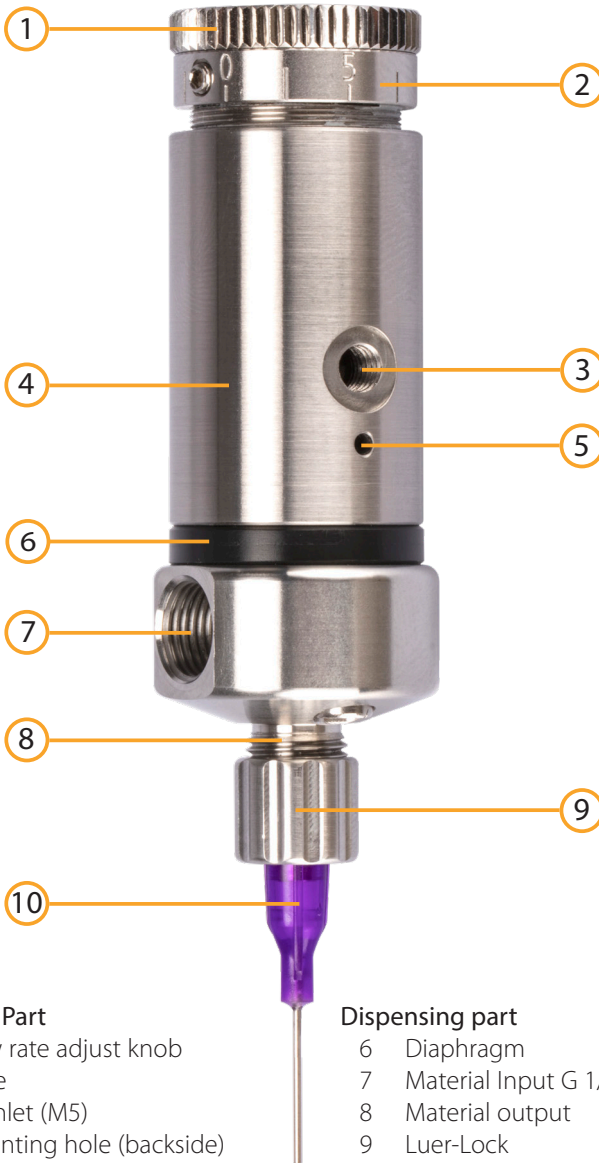

Driving Part

- 1 Flow rate adjust knob
- 2 Scale
- 3 Air inlet (M5)
- 4 Mounting hole (backside)
- 5 Control port for diaphragm

Dispensing part

- 6 Diaphragm
- 7 Material Input G 1/8"
- 8 Material output
- 9 Luer-Lock
- 10 Dispensing tip

4 Operation Principles

Dispensing OFF

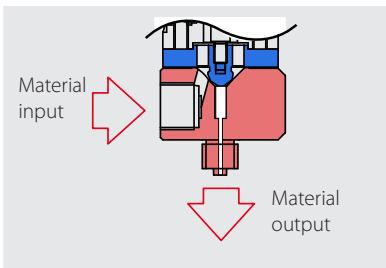
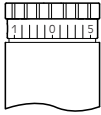

In the "Normal" state (air off), the diaphragm is closed – material is not dispensed.

Since no control air is present, the control parts of the valve are at rest and the diaphragm is closed. This closes the material path and no material is dispensed.

Dispensing ON

Stroke	short	long
Quantity	small	large
Direction		

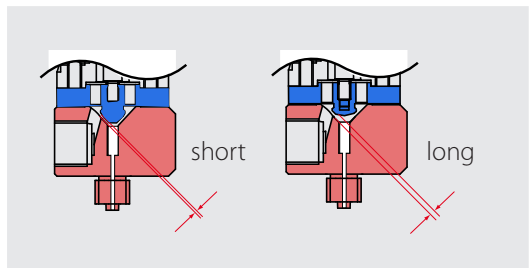

When air is applied, the diaphragm is opened and material is dispensed.

When air is applied to the valve, the diaphragm will open. At this time material will be dispensed.

You can increase or decrease the shot volume by adjusting the stroke (flow rate control knob).

Notice

The maximum stroke length is 0,6 mm (1 rotation). There is no effect after turning the knob more than (1) rotation.

5 Operating Procedure

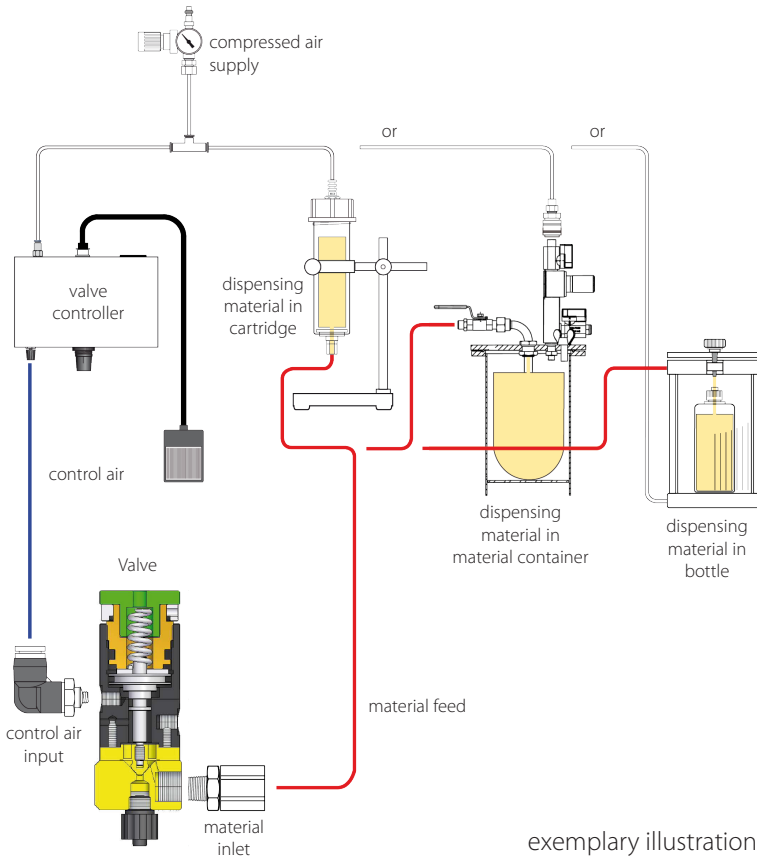

6 Commissioning

1. Fasten the valve firmly using mount hole (M5*P0.8*D98) or use a clamping ring
2. Connect the control compressed air hose to the controller and to the control air input of the dosing valve. The control pressure for the valve must be at least 4,0 bar.
3. Connect the fitting for the material supply to the material inlet 1/8" NPT thread.



Note:

Do not turn the fitting too deeply into the valve.

4. Place a suitable dispensing tip on the material outlet and fix it with the union nut.
5. Set the material pressure as follows (but max. 5.0 bar). Set the material pressure to max. 0.5 bar if you want to dispense very thin material (such as water or solvents). Set the material pressure for highly viscous material to approx. 2.0 bar and adjust it according to the required dispensing.
6. On delivery, the adjusting screw is set to position 3 (center of full stroke). Increase or decrease the setting as required. The maximum stroke is 0.6 mm. This corresponds to a complete turn of the set screw.



Note:

If you turn the adjusting screw 2 turns or more often counterclockwise, the return spring loses its effect and the valve opens continuously. This causes the material to be dispensed continuously, even if no control pressure is applied.

7. Adjust the valve, material pressure, and controller settings so that material slowly exits the valve.
(This prevents bubbles from forming in the dispensing material during dispensing.)
8. Select the operating mode „Timer“ or „Manual“ on the controller depending on the desired dispensing.
9. You can influence the dispensing result using the following 4 options:

Increase or decrease material pressure

Pressure increase leads to increase of dispensing quantity
Pressure reduction leads to a reduction of the dispensing quantity

Diameter of dosing tip

Thin dispensing tip reduces the dispensing quantity
Thick dispensing tip increases the dispensing quantity

Adjusting screw for stroke adjustment

Large stroke setting increases the dispensing quantity
Low stroke setting reduces the dispensing quantity

Dispensing time

Long dosing time increases the dispensing quantity
Short dosing time reduces the dispensing quantity

7 Maintenance

7.1 Cleaning

Clean the valve regularly, especially if you are dosing material that is not intended to be used for hardening, or can lead to possible damage to parts that come into contact with the material.

First empty the material container so that the material path in the valve is as empty as possible and air is still escaping.

Clean the accessible parts that come into contact with the material with a suitable cleaning agent.

Then flush the valve several times alternately with air and a liquid detergents.

7.2 Dismantling the valve

If it is necessary to disassemble the valve for cleaning, use the Exploded view and parts list according to chapter 10.

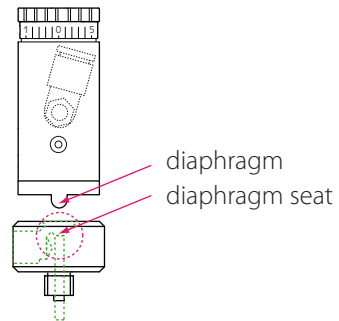

7.3 Assembling the valve

Install diaphragm:

- Turn the adjusting screw counterclockwise out of the valve.
- Remove the valve head.
- Remove the old membrane by turning it counterclockwise.
- Turn in the new diaphragm carefully.



Note:

If the diaphragm has not been screwed in properly, the valve is leaking.

After you have brought the new diaphragm to the correct distance (0.4 mm - see picture) to tighten the compressed air cylinder, turn the diaphragm with a screwdriver to the necessary position according to the following picture.

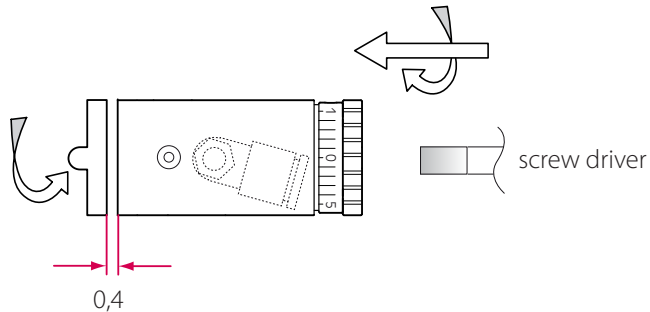

To reassemble the valve head, fix it carefully with the Allen screw.

Turn the adjusting screw back in when the valve is assembled.

After the valve has been completely assembled, turn the adjusting screw back in again.



Note:

The scale may no longer show exactly „0“. In this case, calculate the setting relative to the closed position. This will not affect the operation.

8 Detail drawings & dimensions

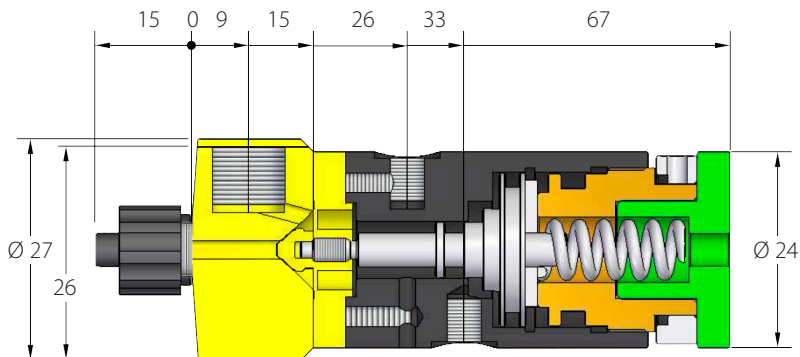

Units of measurement in mm

9 Exploded drawing

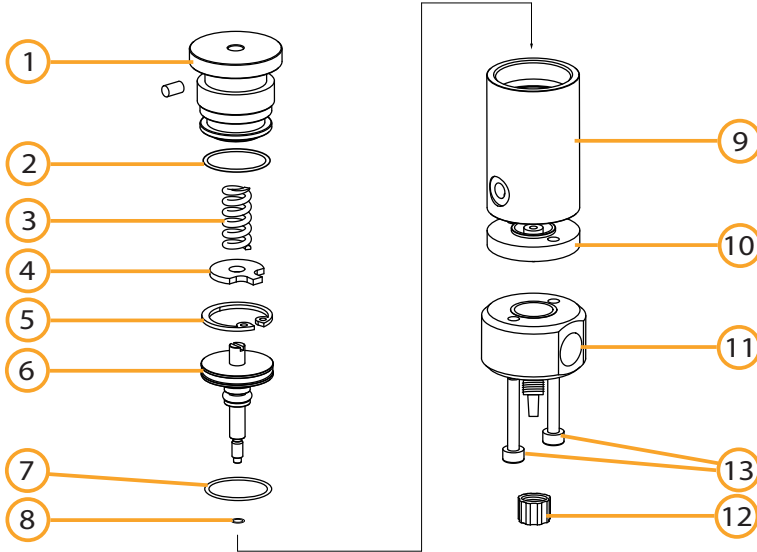

10 Parts and spare parts list

No.	DV-5625-U	DV-5625-SS	DV-5625-T	Description	piece
1		V-0003		adjusting cap	1
2		V-0011		o-ring 15x2	1
3		V-0010		spring	1
4		V-0007		washer	1
5		V-0004		seeger-ring	1
6		V-0006		plunger	1
7		V-0009		r-ring 6x1	1
8		V-0008		r-ring 4x1,75	1
9		V-0002		cylinder	1
10		V-0005	V-0005-01	diaphragm	1
11	V-0001	-	-	valve chamber UHMW-PE	1
11	-	V-0001-SS		valve chamber stainl. steel	1
11	-	-	V-0001-02	valve chamber PTFE white	1
12	Luer-Lock-91	560952A-1/4-28	Luer-Lock-60	Luer-Lock adapter	1
13		V-0012		screws (M3x20)	2
n. i.		V-0036		comp. air fitting 90° M5	1



VIEWEG GmbH
Dosier- und Mischtechnik
Gewerbepark 13
85402 Kranzberg
Germany
Fon +49 8166 6784 -0
Fax +49 8166 6784 -20
info@dosieren.de
www.dosieren.de